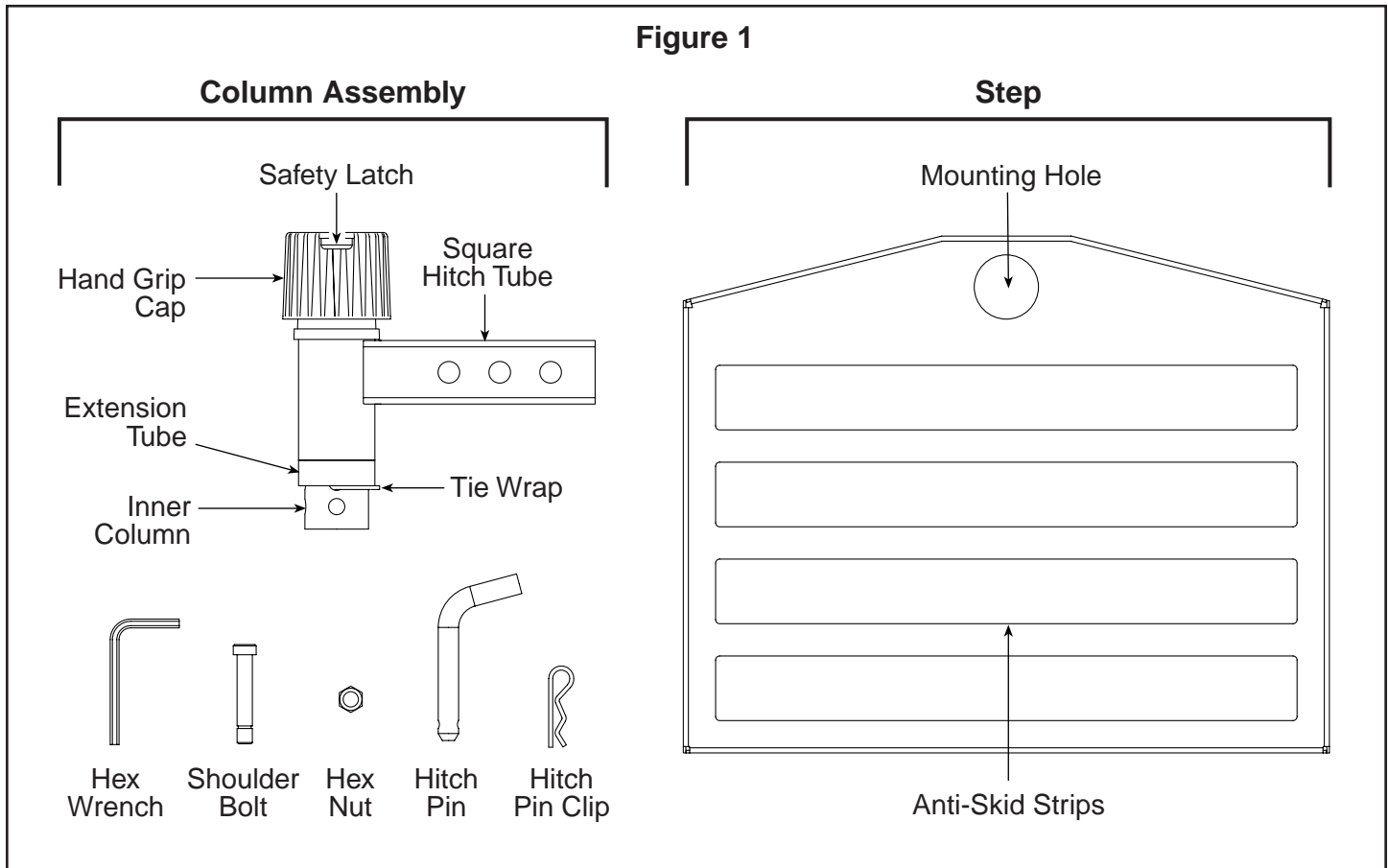

Figure 1



DO NOT REMOVE:

- The tape on the back of the Step until instructed.
- The Tie Wrap on the Column Assembly until instructed.

DO NOT TRY TO DEPRESS THE SAFETY LATCH until the Column Assembly is securely attached to the Step (#5 below). If the Safety Latch is depressed before the Column Assembly is attached to the Step, the whole assembly can come apart.

ASSEMBLY INSTRUCTIONS

1. Remove all of the parts from the box and using Figure #1, ensure that all of the parts are included.
2. Take the Step out of the bag and place the anti-skid strip surface face up on a stable surface — the floor, on the ground, or on a table. Do not remove the tape on the back of the Step until instructed.
3. Take the Column Assembly out of the bag. Do not remove the Tie Wrap until instructed.
4. **CAUTION:** Do not let children or pets play with the plastic bags. Plastic bags can cause death if placed over a child or pet's head. Dispose of the bags immediately after removing the Step and the Column Assembly from their bags.
5. For this next instruction, please ensure you do not depress the Safety Latch on the TWISTEP Column Assembly Hand Grip Cap.

SAFETY

To ensure the safe and best performance from your TWISTEP, please read and follow all instructions, recommendations, and warnings. OTLLC is not responsible for damage or injury due to misuse of the TWISTEP product.

ASSEMBLY

1. Make sure you have the correct TWISTEP model and parts for your vehicle.
2. Make sure that you have the correct/appropriate hitch-receiver for your vehicle, and that it has been correctly installed.
3. Ensure you have assembled TWISTEP correctly. If you have any questions in this regard, please contact TWISTEP at 1.888.284.7742.
4. Ensure that all hardware is securely tightened.
5. Do not dis-assemble the TWISTEP Column Assembly. Return TWISTEP to OTLLC for examination and repair.
6. Do not substitute items for the parts provided.
7. Do not modify this unit or attach any parts to TWISTEP not authorized by OTLLC.

USE

8. Do not stand or ride on TWISTEP while the vehicle is in motion.
9. Ensure the vehicle engine is shut off before using TWISTEP.
10. To prevent injury, always stow TWISTEP out of the way when not in use.
11. Do not use TWISTEP as a platform to carry items while the vehicle is in motion.
12. Do not use TWISTEP as a towing device.
13. Do not rotate TWISTEP while someone is standing on it.
14. Basic safety precautions and close supervision are necessary when TWISTEP is used, especially when it is used by or near children and pets.
15. Do not operate or use TWISTEP when you are tired, ill, or under the influence of alcohol, drugs, or medication.
16. Use TWISTEP only for its intended use as described in this manual/literature.
17. Do not exceed TWISTEP's recommended load of 500 pounds when using a Class III hitch – 2" receiver (or 300 pounds when using a Class II hitch – 1 1/4" receiver).
18. Take appropriate safety precautions if weather conditions warrant (e.g. dry the TWISTEP, remove any ice; be mindful that the TWISTEP may become hot if left out in the sun).
19. Do not overreach while using TWISTEP. Keep proper footing and balance at all times.
20. Stop using your TWISTEP immediately, if it appears unstable, or if damage is visible or if the unit malfunctions or operates intermittently. Never use undue force to operate your TWISTEP.
21. Follow all instructions and warnings. Failure to do so can result in injury. Be thoroughly familiar with the assembly, operation, proper use and maintenance of this product.
22. The TWISTEP is designed to ride higher than the drive and suspension components of your vehicle. Take care when driving in or out of steep driveways or other uneven road surfaces as the TWISTEP could impact the ground in these situations.

CARE AND MAINTENANCE

23. As an extra precaution, we recommend you double check the hitch pin and hitch pin clip as well as all TWISTEP fasteners once a month, to ensure everything is securely fastened and attached, and that nothing has loosened or shifted over time or with vehicle vibration.
24. For proper operating performance, we recommend you clean your TWISTEP from time to time with soap and water, to ensure sand, grit and other debris do not interfere with TWISTEP's smooth operation.
25. Please remember to stow TWISTEP out of the way if you drive through a car wash facility.
26. No lubrication of TWISTEP is required.



OT LLC

2212 Queen Anne Ave N • PMB 712 • Seattle, WA 98109
1.888.284.7742 (toll free) • www.twistep.com • Patent pending

Figure 2

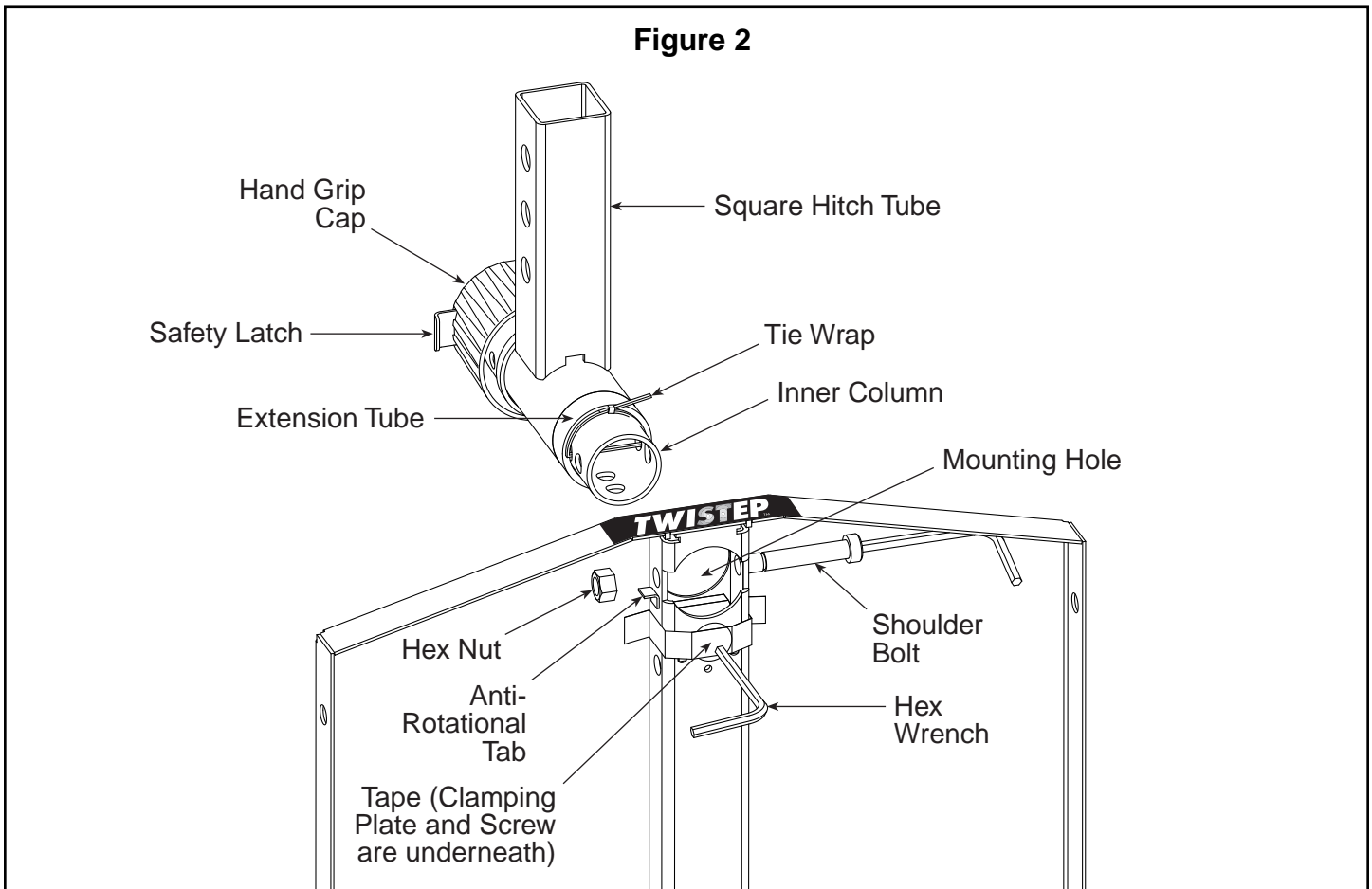

6. Without depressing the Safety Latch, align the Column Assembly with the holes on the assembly's Inner Column, and align the Square Hitch Tube, all as shown in Figure #2.
7. Without depressing the Safety Latch, insert the end of the Column Assembly into the large mounting hole in the center of the Step as illustrated in Figure #2.
8. Note that the Column Clamping Plate and Screw (see Figure #2) are pre-installed on the under side of the Step assembly. The Inner Column Assembly must clear this plate when it's being inserted into the hole on the Step.
9. Once the Column Assembly is inserted into the Step, remove the Tie Wrap by cutting it with a knife or strong pair of scissors.
10. After the Inner Column Assembly has been fully inserted, carefully turn the TWISTEP (Column and Step) over and let it rest on the Column Assembly and edge of the Step.
11. Looking at the under side of the Step, line up the large holes located at the end of the Column Assembly with the pair of holes on the underside of the Step.
12. Insert the Shoulder Bolt through the holes in the underside of the Step and the holes of the Column Assembly.
13. Put the Hex Nut onto the threaded end of the Shoulder Bolt, placing one flat side of the Hex Nut up against the welded Anti-Rotational Tab on the inner support of the Column, as shown in Figure #2.
14. Tighten the Shoulder Bolt securely using the supplied Hex Wrench.
15. Tighten the Clamping Plate on the under side of the Step by removing the tape, and tightening the Screw (in a clockwise direction) with the Hex Wrench provided.
16. Your TWISTEP is now ready to be installed on to your vehicle.

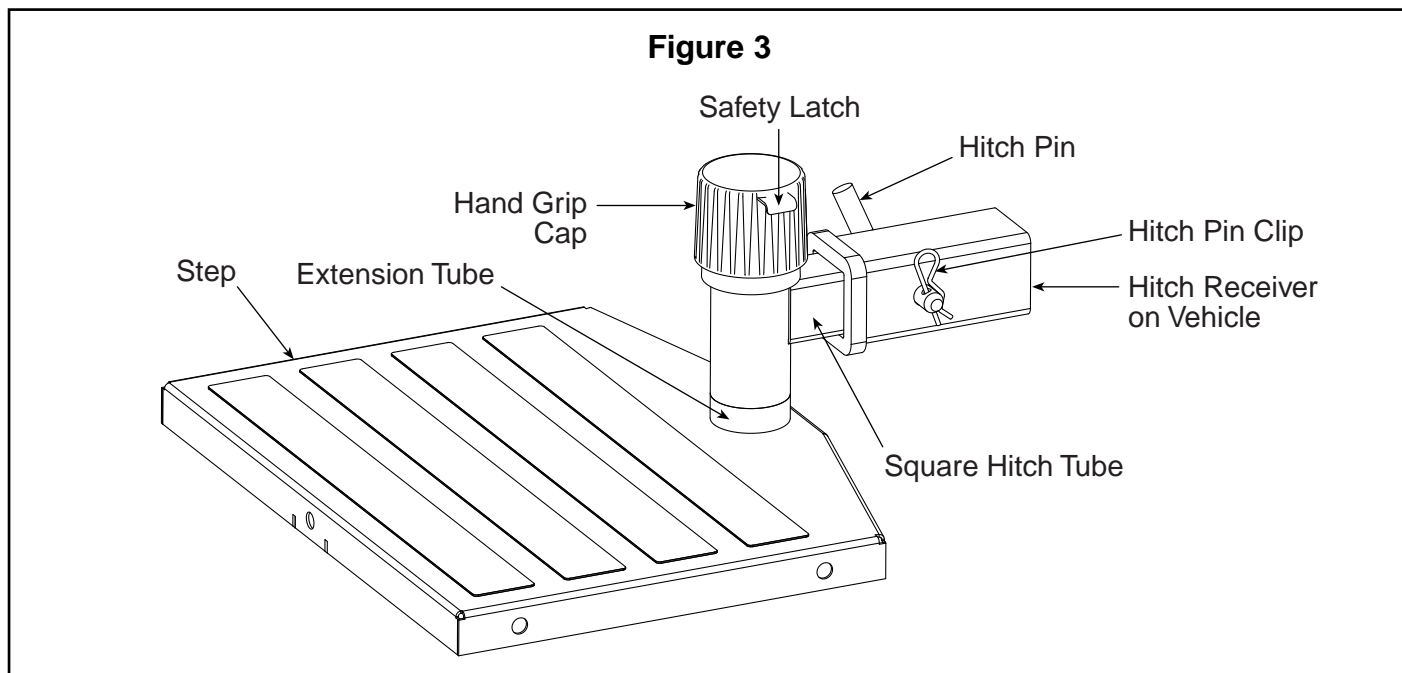

INSTALLATION INSTRUCTIONS

Preliminary Installation and Fit Test Instructions

17. To install the TWISTEP onto your vehicle, slide the Square Hitch Tube attached to the Column Assembly into the hitch receiver.
18. Insert the Hitch Pin through the side hole of the hitch receiver all the way.
19. Insert the Hitch Pin Clip into the small hole of the Hitch Pin.
20. Ensure everything is properly tightened and fastened. You're ready to use your TWISTEP.

CHECKING CLEARANCE BETWEEN TWISTEP AND YOUR VEHICLE

The TWISTEP should be in the stowed position under the bumper. Inspect the clearance between the top of the TWISTEP and the lowest part of the vehicle. If there is more than one inch of clearance between the TWISTEP and the vehicle, you can raise the TWISTEP if desired, by doing the following:

1. Remove the TWISTEP from the vehicle.
2. Remove the Shoulder Bolt.
3. Remove the Step from the Column Assembly. **NOTE:** Be sure NOT to release the Safety Latch or turn the Hand Grip while the Column Assembly is being removed from the Step. The mechanism can come apart.
4. Remove the Column Extension Tube from the Column.
5. Reassemble the Step by following the assembly steps #6-#16. The mounting holes in the Step will now line up with the second set of holes on the Inner Column.
6. Install the TWISTEP back onto the hitch receiver and verify clearance for the vehicle.

TWISTEP USE INSTRUCTIONS

1. To rotate the Step, push the Safety Latch in, towards the Hand Grip/Column.
2. Push down on the Hand Grip (the round cap with the labeled numbers on it).
3. Twist the Hand Grip to rotate the TWISTEP.

NOTE: TWISTEP is designed to stop at four positions; every 90 degrees.



OT LLC

2212 Queen Anne Ave N • PMB 712 • Seattle, WA 98109
1.888.284.7742 (toll free) • www.twistep.com • Patent pending